

# PEARL TWIN PEDAL COMPLETE

# P-152TW

## Instruction Manual

Congratulations on your purchase!  
To get optimum performance of your PowerShifter Pedals,  
please read this Instruction Manual before playing.

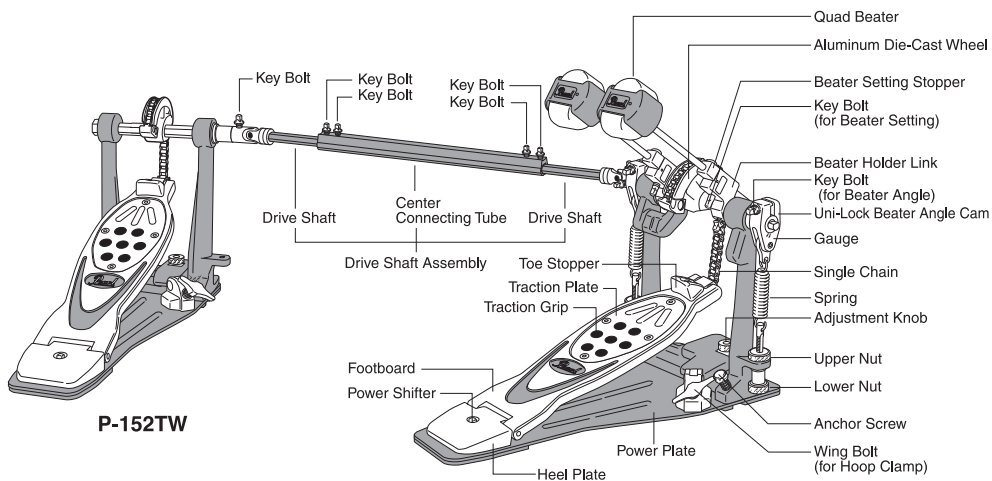

## PowerShifter

The PowerShifter function allows you to change the feel and action of the pedal by shifting the footboard position back and forth. To change the position, loosen the key bolt in the heel of the footboard and move the footboard to the desired position: A, B or C. Tighten the key bolt again ( Drawings #1, #2 ).

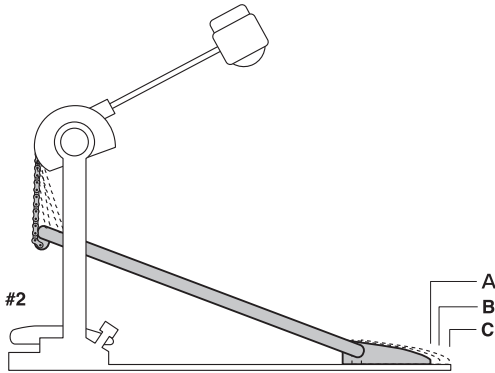

- A. Strong
- B. Normal
- C. Light

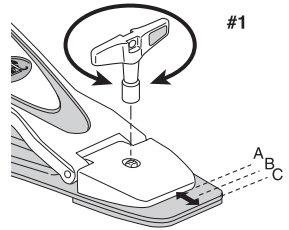

( CAUTION! )  
The heel must be flush with the Power Plate, or damage to the pedal may result.

## Quad Beater

The Quad Beater has four faces, each capable of producing a different sound. Please refer to the following chart to determine the sound best suited to your playing style ( Drawing #3).

- A. Felt Surface / Spot Contact area = Warm Sound with Sharp Attack
- B. Felt Surface / Line Contact area = Warm Sound with Dull Attack
- C. Plastic Surface / Spot Contact area = Hard Sound with Sharp Attack
- D. Plastic Surface / Line Contact area = Hard Sound with Dull Attack

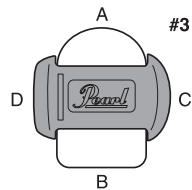

## Beater Setting

Insert the Quad Beater into the Beater Holder Link with the desired face toward the bass drum head. Loosen the Allen screw (with the provided hexagonal wrench) on the Beater Setting Stopper and hold the beater at the desired height. Slide the Beater Setting Stopper into the notch of the Beater Holder Link and securely re-tighten the Allen screw. Then tighten the key bolt to secure the Beater. The Beater Setting Stopper helps prevent the Quad Beater from rotating while playing and keeps the desired setting position for future use ( Drawings #4, #5 ).

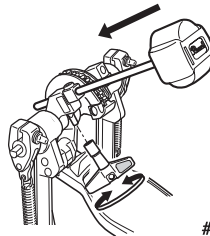

#4

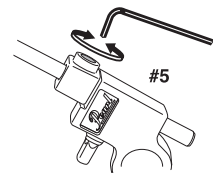

#5

## Beater Angle Adjustment

The beater angle can be adjusted by loosening the key bolt on the Uni-Lock Beater Angle Cam and swinging the beater to the desired angle. Simply re-tighten the key bolt to secure the angle. The desired angle can be easily marked with the gauge on the cam ( Drawing #6 ).

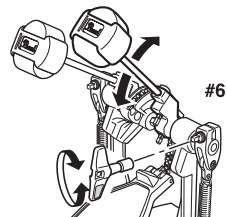

#6

## Spring Tension Adjustment

To adjust spring tension, loosen the Upper Nut then adjust the Lower Nut to the desired spring tension. Counterturn the Upper Nut and Lower Nut to secure the spring tension. ( Drawings #7 )

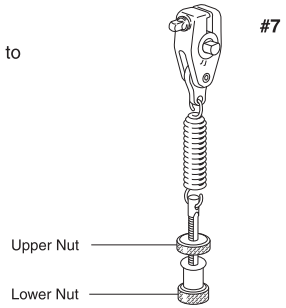

## Traction Plate and Traction Grip Adjustment

The Traction Grip dots can be totally removed or inserted as needed to custom tailor the amount of traction for your personal playing style. The Traction Plate is also reversible to provide just the right amount of grip at either the front or rear of the footboard. To remove the Traction Grip dots, loosen the Allen screws holding the Traction Plate with the provided hexagonal wrench and remove the Traction Plate from the footboard. ( Drawings #8, #9 )

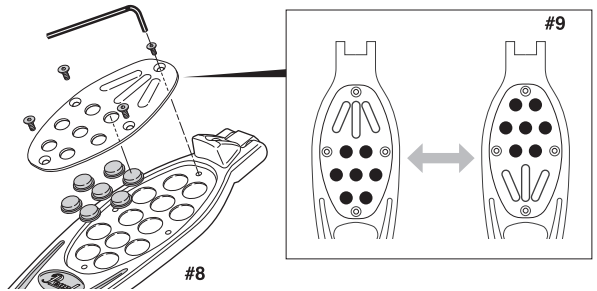

( CAUTION! ) Always use the pedal with the Traction Plate mounted to prevent possible injury to your foot.

## Connecting the Drive Shaft Assembly

Connect the ends of the Drive shaft (A) to the short extensions (B) on the Main and Secondary Pedals. ( Drawings #10 & 11 )

Note :

You may need to rotate the Drive Shaft Assembly to bring the footboard of the secondary (left) pedal to the proper playing height (angle) before attaching the Drive Shaft Joints (A) to both pedals.

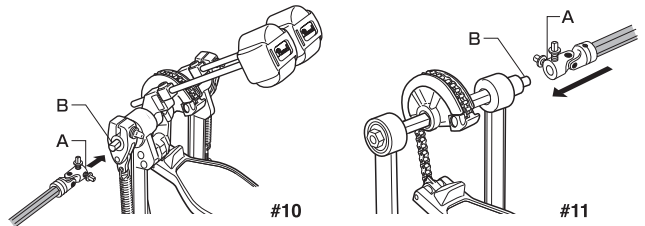

Loosen the key bolts on the Center Connecting Tube of the Drive Shaft Assembly. Adjust the distance between the Main pedal and the Secondary pedal to your liking. Re-tighten the key bolts. (Drawing #12)

Note :

If the drive shafts are extended too far, they will separate from the Center Connecting Tube. Reassemble them with the dots aligned as shown in Drawing #13.

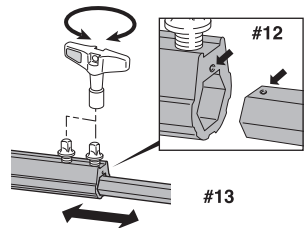

## Toe Stopper

The toe stopper prevents your foot from sliding into the chain or belt while playing. If not needed, it can be removed easily by undoing the key bolt on the footboard. ( Drawing #14 )

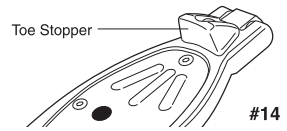

## Hoop Clamp System

The newly designed Hoop Clamp system accepts a wide variety of hoop thickness. To attach your pedal to the bass drum, slide the bass drum hoop between the hoop clamp and the bottom lip of the pedal. Turn the adjustment knob to accommodate the thickness of the hoop, square-up the pedal, then tighten the adjustment knob to secure the pedal to the hoop. If the bass drum hoop doesn't fit or if the heel of the pedal jumps up while playing, loosen the Allen screw with the provided hexagonal wrench and fine adjust the adjustment knob to compensate. Securely tighten the Allen screw when done. ( Drawing #15 )

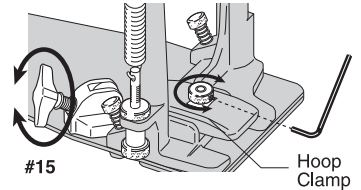

Clamp the provided accessory plate under the hoop clamp of the Secondary (left) pedal to prevent any unwanted noise from the hoop clamp. (Drawing #16)

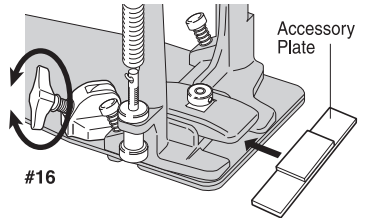

## Anchor Screw

The Anchor Screws can be extended as needed to help prevent the bass drum from creeping forward while playing.

( CAUTION! ) The tips of the Anchor screws are sharp and may damage the surface of the floor.

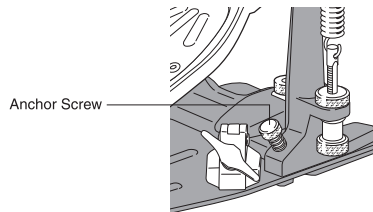

## Optional Pedal Stabilizer ( PS-85 )

To help prevent the Secondary (left) pedal from slipping, the PS-85 Pedal Stabilizer is available separately. The PS-85 features convertible spike/rubber tips and is attached by the hoop clamp of the Secondary (left) pedal.

( CAUTION! ) Use the included hexagonal wrenches to maintain the tightness of all Allen screws. Periodically apply lubrication to all moving parts to insure smooth operation.

**Pearl**<sup>®</sup>  
The best reason to play drums.

Products and specifications are subject to change without notice. Printed in Taiwan.